

Meccanismo PEGASO per ante movimento orizzontale - ammortizzato

Caratteristiche tecniche:

- Meccanismo unico per apertura dx e sx.
- Per mobili larghezza 450 - 600 mm.
- Completo di barra verticale 2000 - 3000 mm.

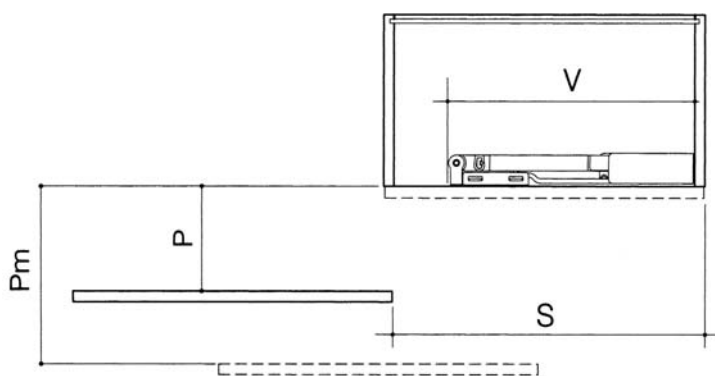
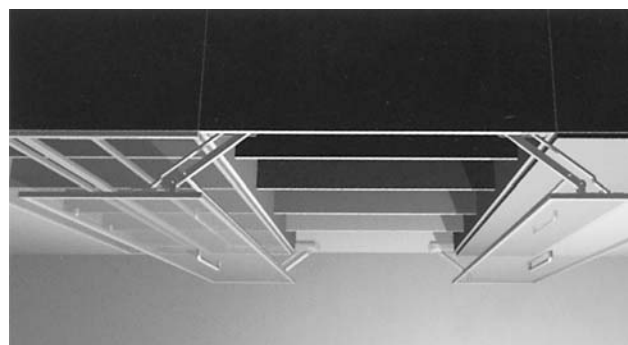

PEXXX450064

V = 398min 474max
 S = 445
 P = 154
 Pm = 257

PEXXX600064

V = 475 min
 S = 583
 P = 196
 Pm = 332

SCHEMA DI FORATURA

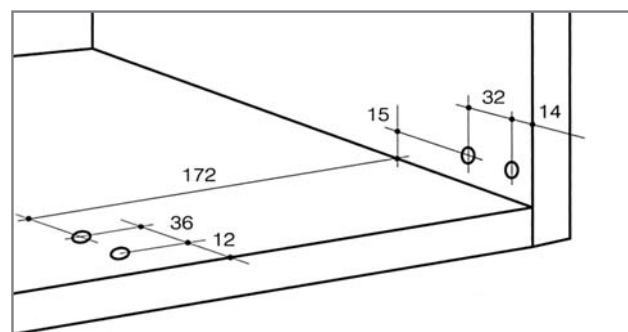
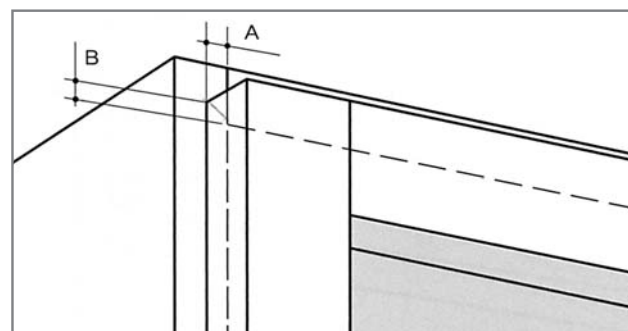
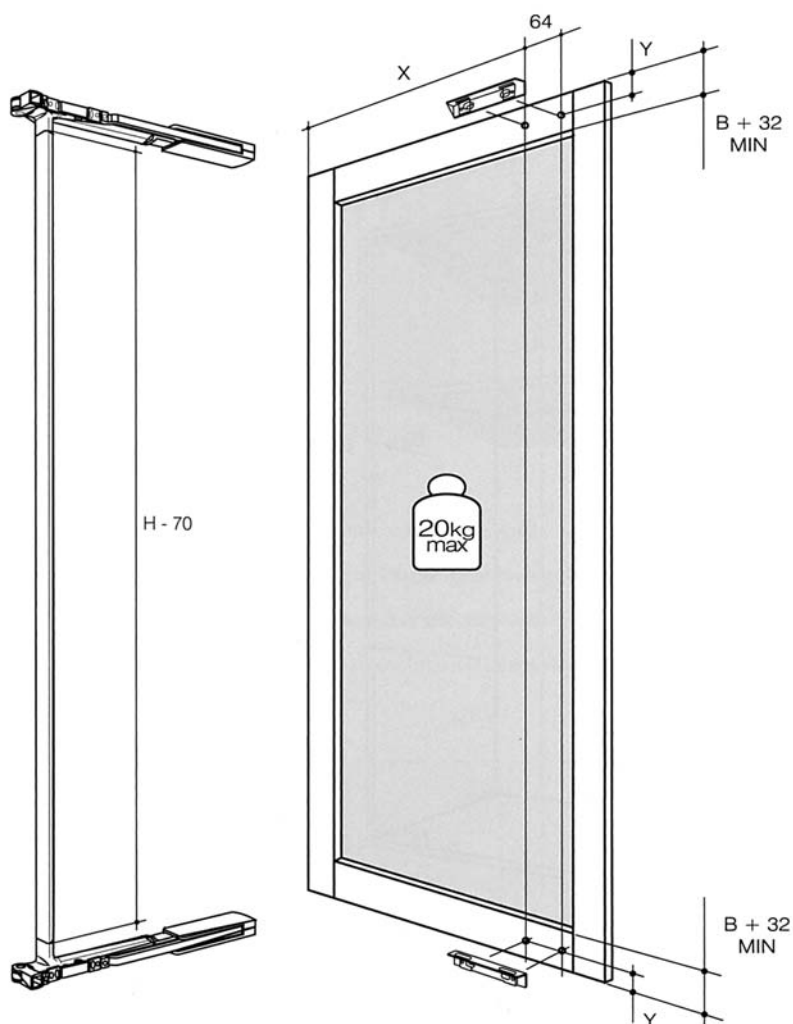

PEXXX450064

L = 398 min
 X = 273 + A
 Y = 17,5 + B

PEXXX600064

L = 475 min
 X = 348 + A
 Y = 17.5 + B